

SpecialRED

UV lighting solutions

UVC linear LED module
275nm, 12 LEDs
with Violet lens



LCE

LED &
COMPONENTS
EXPERT



Features

- PCB dimension: 281x19.2mm
- Up to 800mW
- Peak Wavelength 270-280nm
308/310/325nm UVB available on request
- CC & CV solution
- Connection type: 2060
- Long life referred to the operation condition
- LED Indicator module on
- Customizable current/power



Applications



Safety advices

THIS LED UV product emit ultraviolet light (<400nm). Don't look at operating LEDs. Eye injury may result. Use necessary skin and eyes protection. Assume IEC62471 Risk Group 3.



281x19,2mm UVC led module, 275nm, 12 LEDs

Code	Power class	Vf LED*	Typ Led Current [mA]	Voltage [V]	Power [W]	LED Radiant Flux* [mW]	Radiant Flux* [mW]
R572300UVC01GB	GB-PA	6,2	100	24V - CV	9,6	10	120
				37V - CC	7,4		
R572300UVC01GT	GT-PA		150	24V - CV	14,4	20	250
				37V - CC	11,1		
R572300UVC01GM	GM-PA		250	24V - CV	24	35	400
				37V - CC	18,5		
R572300UVC01GZ	GZ		350	24V - CV	33,6	50	560
				37V - CC	25,9		

* Typical Value refers to datasheet Tj=25°C
Flux Tolerance +/- 7%
Vf Tolerance +/-0,05V

*Value refers to Spectrometer test
Test Conditions:
Temperature: 26°C Int. 24,31°C
Humidity: 25%

See LED datasheet to confirm data are up to date & max Radiant Flux

Led and board features	
Led number	12
Led	LITEON
Circuit	3S2P x 2 / CV with Costant current IC control
Material	MCPCB
Solder	BLACK
Connections	
Cable	NA
Connectors	2060
Power	
Abs. Max Input current CC	1000mA
Mechanical Data	
H x L	19,2x281 mm
Thickness	1,6mm
Conditions	
Max. temp. (Tp)	60°C
Max. temp. (Tc)	65°C
Operating temp. Range	-20+40°C

281x19,2mm UVC led module, 275nm, 12 LEDs

Mechanical drawing

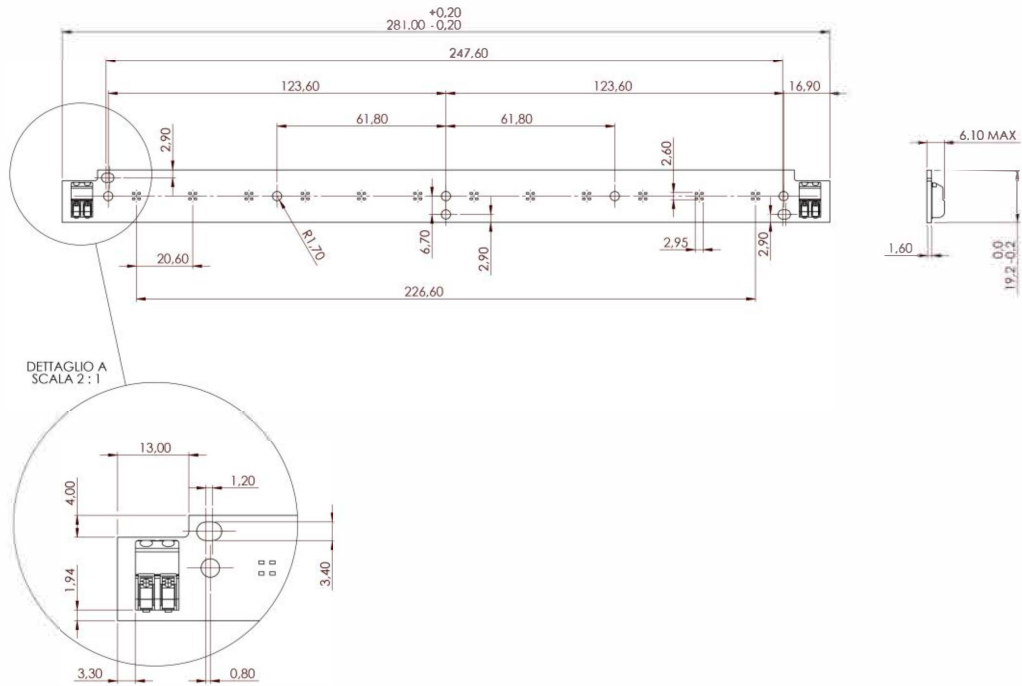

Electrical circuit

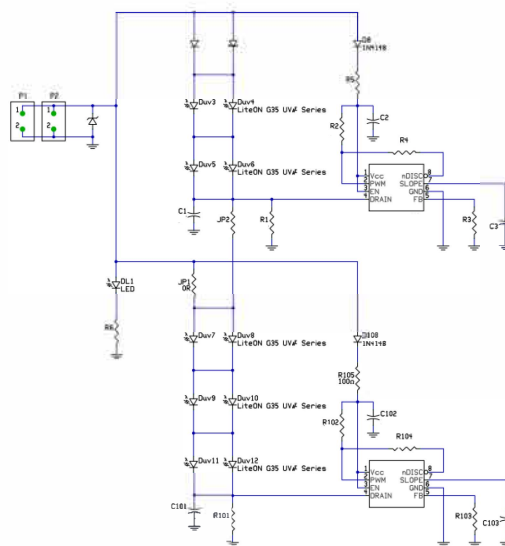

281x19,2mm UVC led module, 275nm, 12 LEDs

Relative spectral distribution

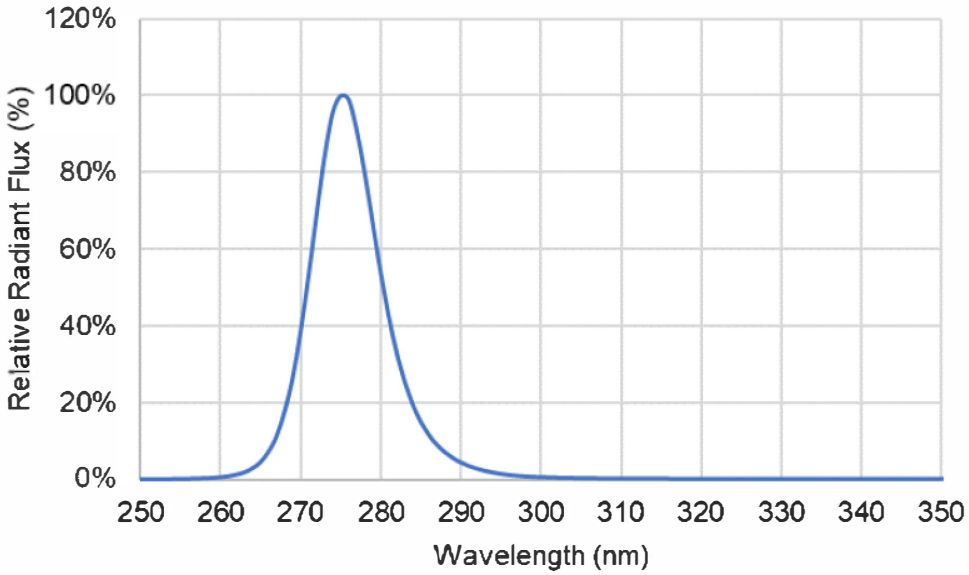

Radiation characteristics

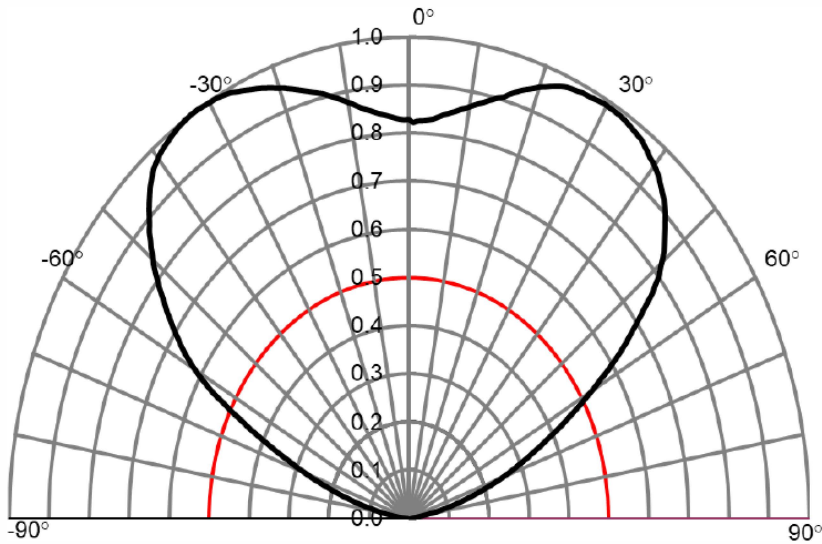



Specifications	
View Angle (Fwhm)	~20°
Material	Clear Silicon
Led series	Liteon LTPL-G35UVC-xx
Product description	
Type	FN17294_VIOLET-12X1-S
Reflective Efficiency	72%
Use Temperature	>100°c
Certification	ROHS
Dimensions	294.8 x 41.6 mm x 8,8mm height

Assembly and Safety Information

Installation must be carried out under observation of the relevant regulations and standards. The LED modules are designed for operation within a casing or luminaire. Installation must be carried out in a voltage-free state (i.e. disconnection from the mains).

The following advice must be observed; non-observance can result in the destruction of the LED assembly modules, fire and/or other hazards.

- Consider safety regulations acc. EN 60598 in the luminaire design, especially when the operating LED driver is not galvanic isolated.
 - In mode of operation regard to sufficient isolation.
 - Live parts must not be touched in operation mode. Danger in life!!!
- ESD (electrostatic discharge) protection measures must be observed when handling and installing the LED modules. See VS's application notes on ESD protection.
- Adequate anti-static electricity measures, including the use of conductive shoes, ionizers, work bench grounding, wrist straps, flooring and stools should be used.
- LED assembly modules must not be subjected to any undue mechanical stress, e. g.:
 - do not treat as bulk cargo
 - avoid shear and compressive forces during handling and installation
 - do not damage circuit paths
 - avoid any pressure on the light emitting surface
- Safe operation only possible by the use of external constant current sources (Imax. see table "Electrical Characteristics").
- Operation only with power supply units that feature the following protection:
 - Short-circuit protection
 - Overload protection
 - Overheating protection
- The module can be fixed with M3 screws. Fixation only with flat or cylinder head screws (M3) (no countersank screws) Max. torque: 1.2 Nm (M3)
- Please ensure the correct polarity of the leads prior to commissioning. Reversed polarity can destroy the modules.
- For interconnection the LED modules is equipped with push-in terminals (WAGO 2060).
- Safety regulations acc. to EN 60598 (or further standards) has to be observed if the maximum output voltage exceed the permitted touchable value.
- The following points must be observed when connecting LED modules in parallel:
 - All LED strings that are wired in parallel must contain the same number of LEDs (symmetrical loading).
 - Owing to differing forward biases, there can be a difference of up to 10% in brightness between modules connected in parallel.
- To ensure problem-free operation, the specified maximum temperature at the tp point (see "Operating Life") must be observed (and measured in accordance with EN 60598-1). To satisfy this point, it may be necessary to put measures in place to ensure any heat is dissipated from the PCB to the environment.
- In the event of outdoor applications or applications in damp locations, care must be taken to protect LED assembly modules against humidity, splashes and jets of water. Any corrosion damage resulting from humidity or contact with condensation will not be recognized as a defect or manufacturing fault. LED assembly modules are not specially protected against foreign bodies or dust. Depending on the type of application, further protection must be ensured to prevent dust and foreign bodies from entering.
- Due to the manufacturing process, the PCBs of the LED assembly modules can have sharp edges and corners. Care must therefore be taken during handling and installation to avoid injury.
- For optimal load of used constant current driver the modules can only be connected in series. The quantity of LED modules is limited by the sum of forward voltage and the capacity of used constant current driver. Safety regulations acc. to EN 60598 has to be observed if the sum of forward voltage exceed the permitted touchable value.
- Operating LED modules in the presence of certain chemical substances or in chemically enriched (aggressive) environments can impair module functionality or even cause total module failure.
- The photobiological safety of the LED modules must be classified into risk groups in accordance with IEC / TR 62778:
 - risk group 1 (except HB, 6500 K, > 500 mA: risk group 2)

Applied Standards

IEC / EN 62031
LED modules for general lighting – Safety specifications

IEC / TR 62778
Application of IEC 62471 for the assessment of blue light hazard to light sources and luminaires