

Features

- PCB dimension: 145x145mm
- Up to 2498 lm
- Up to 148 lm/W
- CRI 80, 90
- Max Electrical Insulation 250V
Max 6 LED boards in series
- NTC available on request
- Connection type: WAGO 2060-451/998-404
- Lifetime >60000h @ 500mA



Applications



Downlight



Indoor

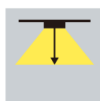

Low Bay



Office

Square LED module, 145x145mm, 72 LEDs

Code	CCT	CRI	Current [mA]	Voltage [V]	Power [W]	Total Lumen* [lm]	lm/W	Energy Efficiency
R4675013090100	3000K	90	500	33,7	16,85	2383	141	E
R4675014090100	4000K			33,7	16,85	2498	148	D

* Typical Value refers to datasheet Tj=25°C
Flux Tolerance +/- 7%
Vf Tolerance +/- 0,06V

CONDIZIONI DA VERIFICARE SUL DATASHEET DEL LED

*Value refers to Spectrometer test
Test Conditions:
Temperature: 26°C Int. 24,31°C
Humidity: 25%

Led and board characteristics	
Led number	48+24
Led	CREE 2835
Circuit	S12P6 OR S4P6+S8P6 (Optional double lighting)
Material	FR4
Solder	White
Connections	
Cable	Solid 0,2-0,75 mm ² (AWG 24 to 18) standard 0,25-0,34 mm ²
Connector	4 x WAGO 2060-451/998-404
Power	
Abs. Max Input current CC	1050mA
Mechanical Data	
H x L	145x145mm
Thickness	6.1mm
Conditions	
Max. temp. (Tp)	85°C
Max. temp. (Tc)	75°C
Operating temp. Range	-25°C +50°C

Square LED module, 145x145mm, 72 LEDs

Mechanical drawing

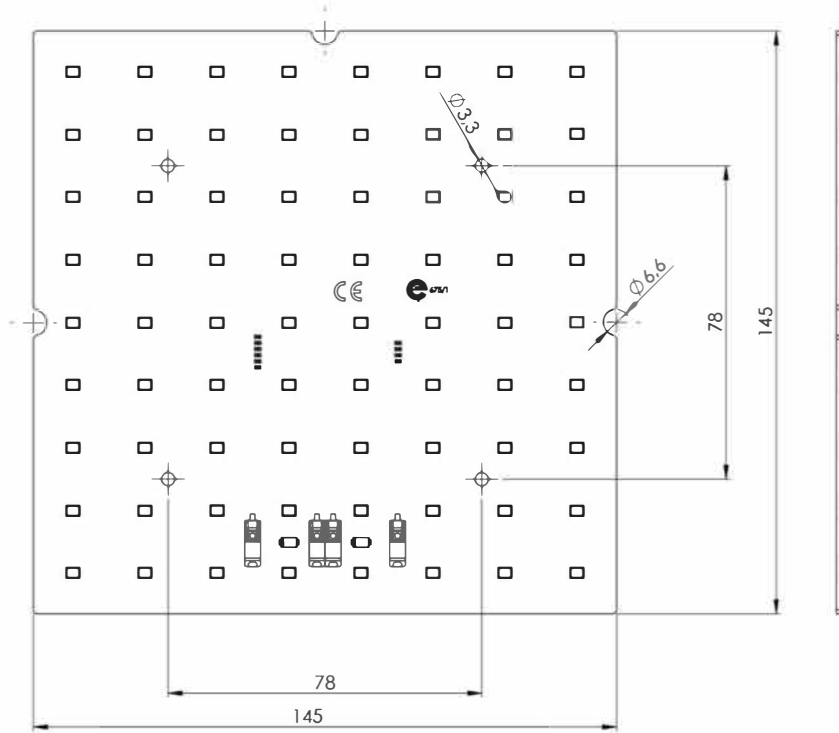

Electrical circuit

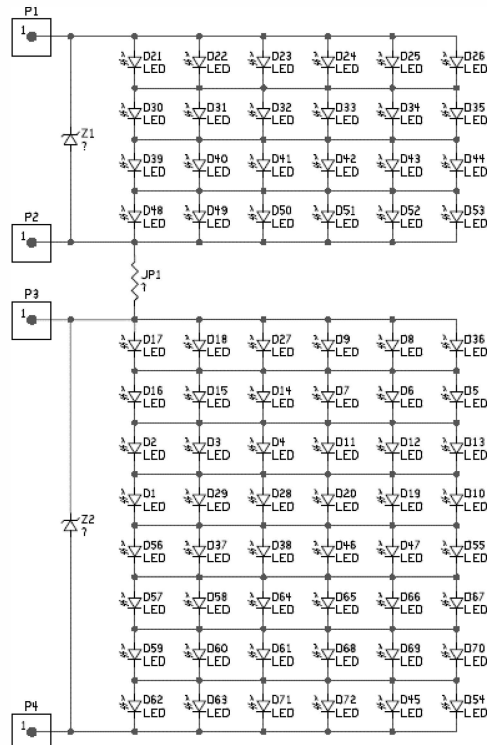

Assembly and Safety Information

Installation must be carried out under observation of the relevant regulations and standards. The LED modules are designed for operation within a casing or luminaire. Installation must be carried out in a voltage-free state (i.e. disconnection from the mains).

The following advice must be observed; non-observance can result in the destruction of the LED assembly modules, fire and/or other hazards.

- Consider safety regulations acc. EN 60598 in the luminaire design, especially when the operating LED driver is not galvanic isolated.
 - In mode of operation regard to sufficient isolation.
 - Live parts must not be touched in operation mode. Danger in life!!!
- ESD (electrostatic discharge) protection measures must be observed when handling and installing the LED modules. See VS's application notes on ESD protection.
- Adequate anti-static electricity measures, including the use of conductive shoes, ionizers, work bench grounding, wrist straps, flooring and stools should be used.
- LED assembly modules must not be subjected to any undue mechanical stress, e. g.:
 - do not treat as bulk cargo
 - avoid shear and compressive forces during handling and installation
 - do not damage circuit paths
 - avoid any pressure on the light emitting surface
- Safe operation only possible by the use of external constant current sources (Imax. see table "Electrical Characteristics").
- Operation only with power supply units that feature the following protection:
 - Short-circuit protection
 - Overload protection
 - Overheating protection
- The module can be fixed with M3 screws. Fixation only with flat or cylinder head screws (M3) (no countersank screws) Max. torque: 1.2 Nm (M3)
- Please ensure the correct polarity of the leads prior to commissioning. Reversed polarity can destroy the modules.
- For interconnection the LED modules is equipped with push-in terminals (WAGO 2060).
- Safety regulations acc. to EN 60598 (or further standards) has to be observed if the maximum output voltage exceed the permitted touchable value.
- The following points must be observed when connecting LED modules in parallel:
 - All LED strings that are wired in parallel must contain the same number of LEDs (symmetrical loading).
 - Owing to differing forward biases, there can be a difference of up to 10% in brightness between modules connected in parallel.
- To ensure problem-free operation, the specified maximum temperature at the tp point (see "Operating Life") must be observed (and measured in accordance with EN 60598-1). To satisfy this point, it may be necessary to put measures in place to ensure any heat is dissipated from the PCB to the environment.
- In the event of outdoor applications or applications in damp locations, care must be taken to protect LED assembly modules against humidity, splashes and jets of water. Any corrosion damage resulting from humidity or contact with condensation will not be recognized as a defect or manufacturing fault. LED assembly modules are not specially protected against foreign bodies or dust. Depending on the type of application, further protection must be ensured to prevent dust and foreign bodies from entering.
- Due to the manufacturing process, the PCBs of the LED assembly modules can have sharp edges and corners. Care must therefore be taken during handling and installation to avoid injury.
- For optimal load of used constant current driver the modules can only be connected in series. The quantity of LED modules is limited by the sum of forward voltage and the capacity of used constant current driver. Safety regulations acc. to EN 60598 has to be observed if the sum of forward voltage exceed the permitted touchable value.
- Operating LED modules in the presence of certain chemical substances or in chemically enriched (aggressive) environments can impair module functionality or even cause total module failure.
- The photobiological safety of the LED modules must be classified into risk groups in accordance with IEC / TR 62778:
 - risk group 1 (except HB, 6500 K, > 500 mA: risk group 2)

Applied Standards

IEC / EN 62031
LED modules for general lighting – Safety specifications

IEC / TR 62778
Application of IEC 62471 for the assessment of blue light hazard to light sources and luminaires