



STEFFI-D AC



25° | 50°

STEFFI-D

3W | 5W | 7W | 10W

A qualified solution for downlights and spotlights.
No Driver is required!





Steffi-D LED Module:

Crafting Atmosphere with Unmatched Performance

Story: Steffi-D is specifically crafted for downlights and environments where creating a welcoming and comfortable ambiance is essential—whether it’s for social interactions or professional tasks. These AC LED light engines come with integrated drivers, offering not only exceptional performance but also the flexibility and ease of installation designers seek.



By integrating control electronics into the design, we eliminate the need for external drivers or complex wiring setups. Steffi-D offers flicker-free dimming and optimized color stability, ensuring a consistent lighting experience in both architectural and commercial settings. Whether you are designing for restaurants, hotels, medical offices, or residential projects, Steffi-D provides the versatility needed to adapt to any environment.

Key Features:

1. Integrated Smart Drivers

- Built-in drivers providing seamless dimming and flicker-free performance, making it easy to achieve the perfect lighting tone.

2. Effortless Connectivity

- Directly connects to 230VAC with no external drivers required, significantly simplifying installation.

3. Superior Dimming Capabilities

- Our modules support both standard and smart control protocols, ensuring smooth, flicker-free dimming across different environments.

4. High Efficiency

- Engineered for maximum energy efficiency, delivering excellent light output without compromise.

5. Optimized Uniformity

- Our LED modules guarantee consistent color rendering and output, creating uniform lighting across the entire installation.

6. Sustainable and Future-Ready

- Designed in accordance with the latest EU circular economy directives, making it eco-friendly, efficient, and future-proof.



Steffi-D AC

Document no:
n/a

Revision:
2.1

Page:
Page 3 of 20

Object:
Datasheet Steffi-D AC.P.230.32.zyy-NN

Author:
SL

Date:
2024-10-21

Content

Steffi-D LED Module:.....	2
Short form Characteristics	4
Article number structure.....	5
Ordering data	7
Dimensions LED module	8
Mounting instructions.....	9
Wiring diagram	9
Parameters of the Lens system	10
Parameters of the light output.....	11
Binning structure graphical representation	13
Electrical Optical Data	14
Lifetime (Calculated).....	15
Verification of Conformity.....	16
Light fitting routine tests.....	16
DIMMERS tested.....	17
Precautions for use	18
ROHS III Compliant.....	19



Steffi-D AC

Document no:
n/a

Revision:
2.1

Page:
Page 4 of 20

Object:
Datasheet Steffi-D AC.P.230.32.zyy-NN

Author:
SL

Date:
2024-10-21

Short form Characteristics

MODULE CHARACTERISTICS	3 W	5W	7W	10W
Power +/-10% ea.	3 W	5 W	7 W	10 W
Input voltage	230VAC			
Number of LED's	32 CSP			
Colour Rendering Index	>Ra90			
Colour temperature	2700K, 3000K, 4000K			
Optics	25° and 50°			

MECHANICAL

Module dimension with cover	44.7 mm diameter			
Weight				
Assembly holes	3 x 2 mm			
Wire connector	JST BHR-02(4.0)VS-1N or CviLux CP0402S0000			

ELECTRICAL

Input voltage range	220-240V			
Input current +/- 10%	14 mA	22 mA	30 mA	43 mA
Peak inrush current	600mA			
Inrush current duration	< 35µs			
Power factor	PFC 0.95			
Total harmonic distortion	<15% THD			
Type of current	AC			
Surge protection	1.5kV			
Burst protection	2kV			
Over temp. protection	130°C			
Energy class	F			

PHOTOMETRICAL

Flux nominal	280 lm	425 lm	595 lm	870 lm
Efficiency	85 lm/W	85 lm/W	85 lm/W	87 lm/W
SDCM (Mac Adam)	3			
SVM	0.3			
PstLM	0.3			

ENVIRONMENTAL

Temperature range	-40°C to 85°C (Absolute maximum temp Tc 85°C)			
Relative Humidity	10-75%			
Ambient air pressure	500-1060 HPa			

LIFETIME

Life length L70B10*	>50 000h			
---------------------	----------	--	--	--

* Lifetime based on LM80 and interpolation according to TM21 standard.



Steffi-D AC

Document no:
n/a

Revision:
2.1

Page:
Page 5 of 20

Object:
Datasheet Steffi-D AC.P.230.32.zyy-NN

Author:
SL

Date:
2024-10-21

Article number structure

Steffi-D AC.P.230.32.zyy-NN.FF

STEFFI:	Module name (Platform)
AC:	AC= 230VAC, ED=External Driver required, ID=Internal Driver
P:	Power (Watt)
V:	Voltage: 230VAC
n:	Amount of LEDs
8:	CRI: 8=Ra>80, 9=Ra>90
yy:	CCT: 27 =2700K, 30 =3000K, 40 =4000K
NN	Viewing angle code (NN with out optic)
FF	Flickerfree according to EPREL



Steffi-D AC

Document no:
n/a

Revision:
2.1

Page:
Page 6 of 20

Object:
Datasheet Steffi-D AC.P.230.32.zyy-NN

Author:
SL

Date:
2024-10-21

Parameters vs. Article no

ARTICLE NAME	POWER	CURRENT	LEDS	CRI	CCT	LENS	Energy Class
Steffi-D AC.3.230.32.927-25.FF	3	230	32	90	2700	25°	F
Steffi-D AC.3.230.32.930-25.FF	3	230	32	90	3000	25°	F
Steffi-D AC.3.230.32.940-25.FF	3	230	32	90	4000	25°	F
Steffi-D AC.5.230.32.927-25.FF	5	230	32	90	2700	25°	F
Steffi-D AC.5.230.32.930-25.FF	5	230	32	90	3000	25°	F
Steffi-D AC.5.230.32.940-25.FF	5	230	32	90	4000	25°	F
Steffi-D AC.7.230.32.927-25.FF	7	230	32	90	2700	25°	F
Steffi-D AC.7.230.32.930-25.FF	7	230	32	90	3000	25°	F
Steffi-D AC.7.230.32.940-25.FF	7	230	32	90	4000	25°	F
Steffi-D AC.10.230.32.927-25.FF	10	230	32	90	2700	25°	F
Steffi-D AC.10.230.32.930-25.FF	10	230	32	90	3000	25°	F
Steffi-D AC.10.230.32.940-25.FF	10	230	32	90	4000	25°	F
Steffi-D AC.3.230.32.927-50.FF	3	230	32	90	2700	50°	F
Steffi-D AC.3.230.32.930-50.FF	3	230	32	90	3000	50°	F
Steffi-D AC.3.230.32.940-50.FF	3	230	32	90	4000	50°	F
Steffi-D AC.5.230.32.927-50.FF	5	230	32	90	2700	50°	F
Steffi-D AC.5.230.32.930-50.FF	5	230	32	90	3000	50°	F
Steffi-D AC.5.230.32.940-50.FF	5	230	32	90	4000	50°	F
Steffi-D AC.7.230.32.927-50.FF	7	230	32	90	2700	50°	F
Steffi-D AC.7.230.32.930-50.FF	7	230	32	90	3000	50°	F
Steffi-D AC.7.230.32.940-50.FF	7	230	32	90	4000	50°	F
Steffi-D AC.10.230.32.927-50.FF	10	230	32	90	2700	50°	F
Steffi-D AC.10.230.32.930-50.FF	10	230	32	90	3000	50°	F
Steffi-D AC.10.230.32.940-50.FF	10	230	32	90	4000	50°	F



Steffi-D AC

Document no:
n/a

Revision:
2.1

Page:
Page 7 of 20

Object:
Datasheet Steffi-D AC.P.230.32.zyy-NN

Author:
SL

Date:
2024-10-21

Ordering data

Steffi-D AC – Packaging information

Description	Qty (pcs)	Dimension (cm)			GW (kg)
		Length	Width	Height	
Inner box	120	35.6	22.7	9.6	1.5
Outer box	960	46.5	37.5	39.6	12.4

Dimensions LED module

Steffi-D LED Module

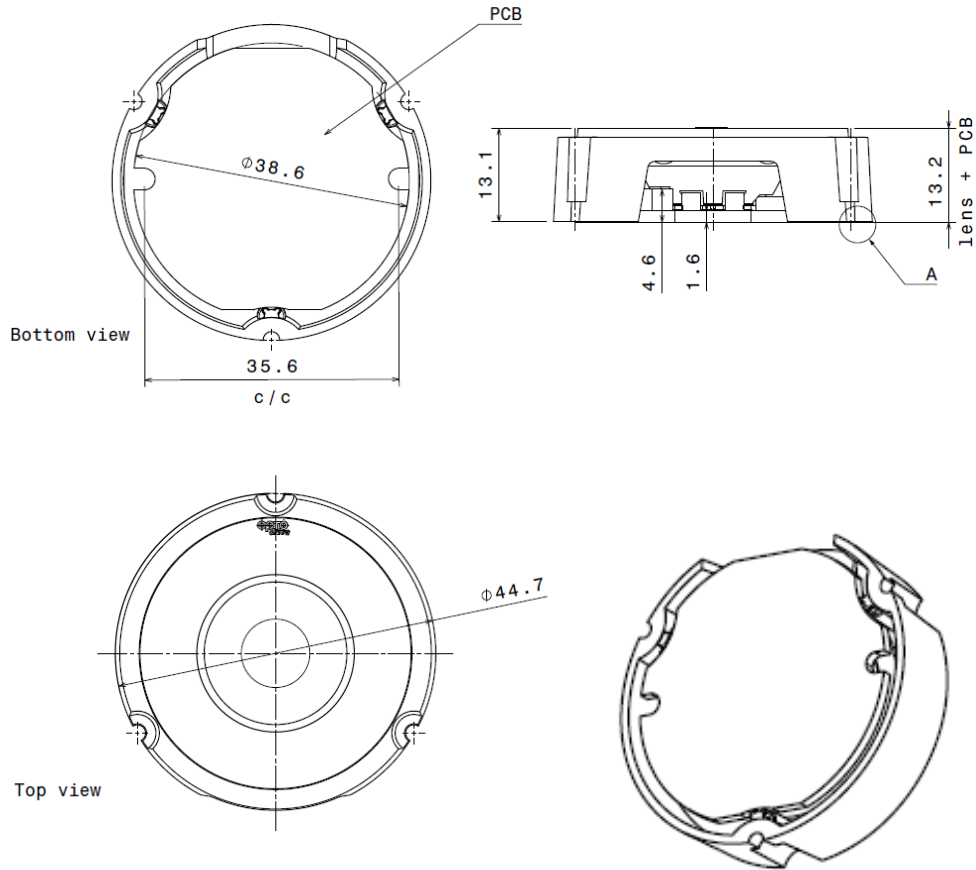



Steffi-D AC

Document no:
n/a

Revision:
2.1

Page:
Page 9 of 20

Object:
Datasheet Steffi-D AC.P.230.32.zyy-NN

Author:
SL

Date:
2024-10-21

Mounting instructions

The unit shall not have any mounting screws directly on the circuit board but only mounted with mounting screws on the lens as our generic model is shown.

Important!
The LED Module have to be fixed with screws properly to secure the user from Hazard Voltage.

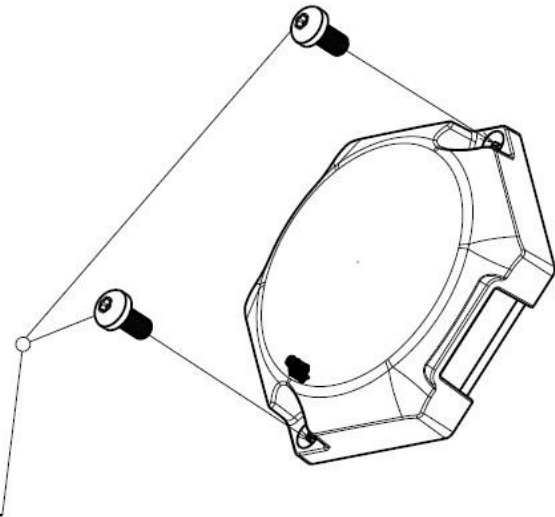

Wiring diagram

ARTICLE NUMBER	ARTICLE NAME	LENGTH
103817	Wire AC 220mm 2-pol	220mm

See separate wiring diagram documentation in Datasheet Accessories AC.

Parameters of the Lens system

Beam cone 10W 3000K

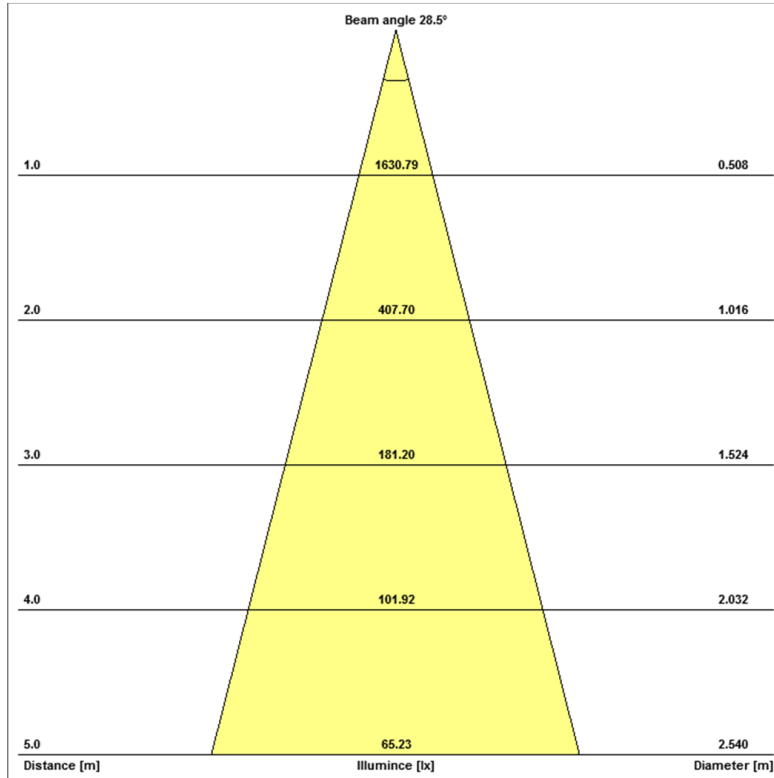

Light intensity distribution diagram 10W 3000K

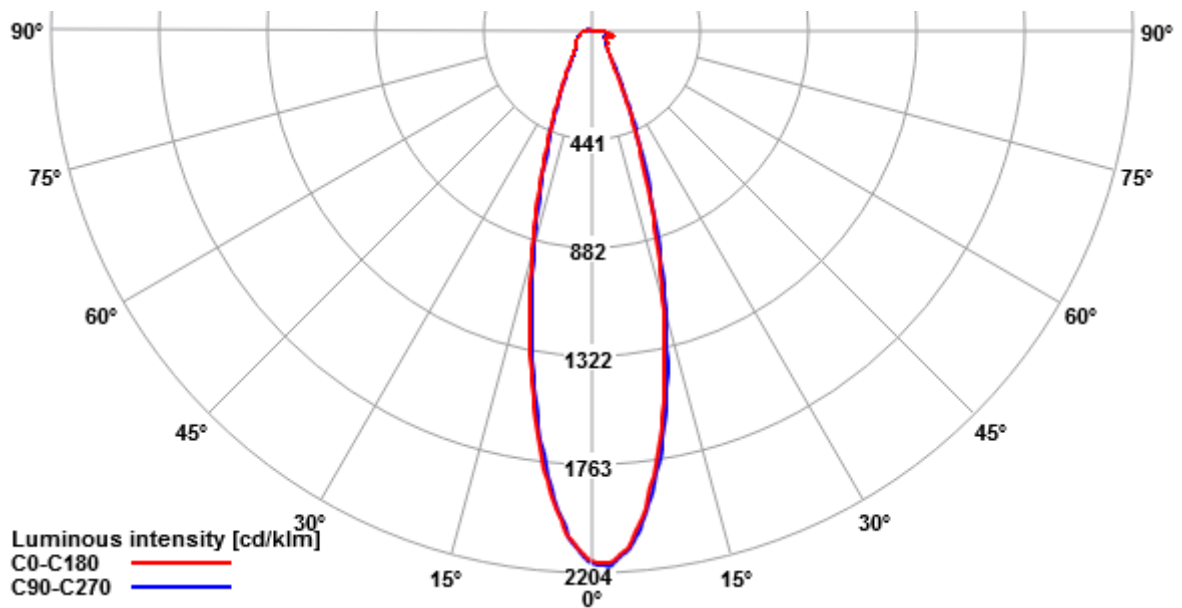



Parameters of the light output

Colour Spectrum

2700K

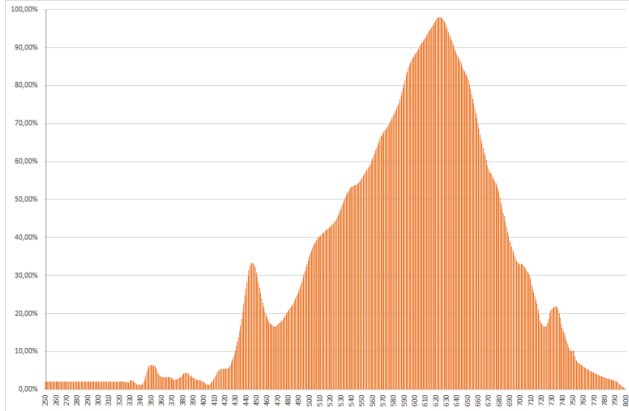

3000K

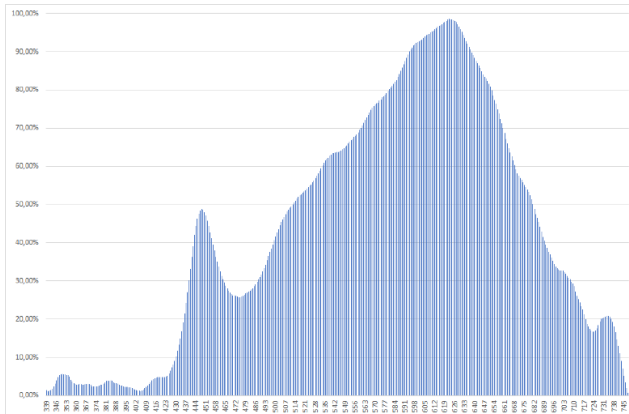

4000K

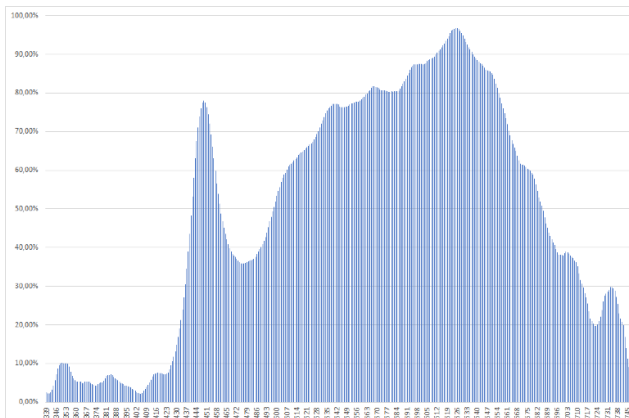

CIE1931

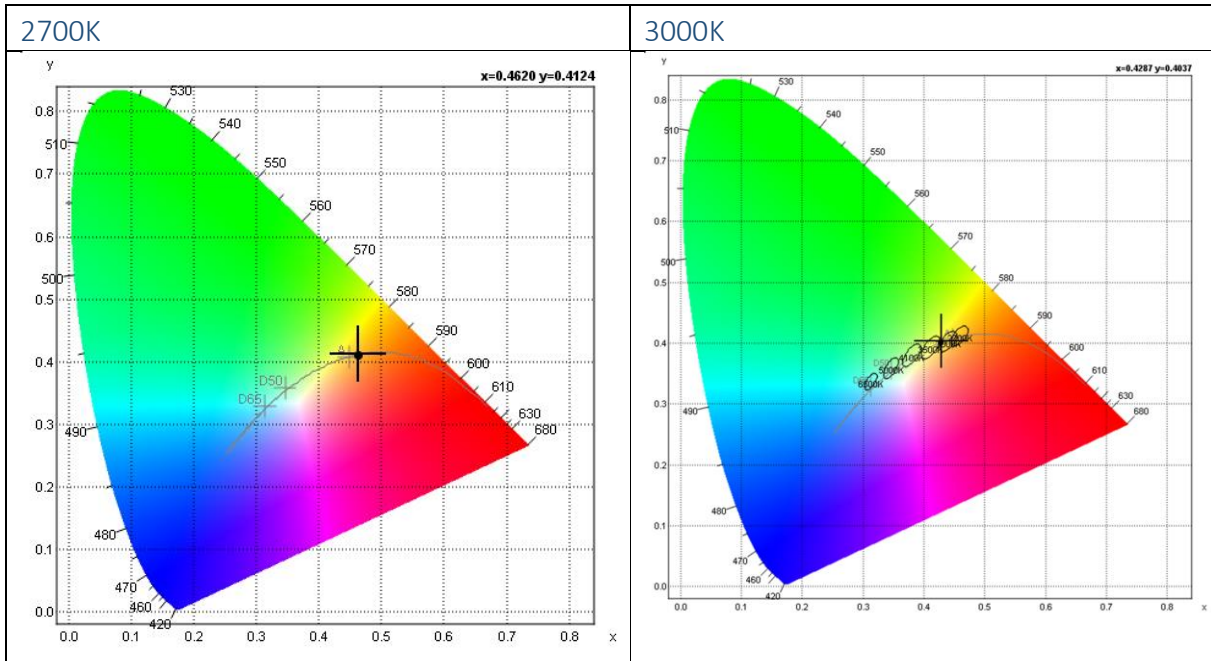

Measurement results including CRI

CIE 1931 2° observer	
x	0.4525
y	0.4037
u'	0.2608
v'	0.5236
L	100.00
a	28.24
b	62.21
X	667.60
Y	595.64
Z	212.08

Other	
CCT	2751
Chromaticity Error	0.003
Color Peak	630.26
Color Peak Value	13.94
Color Dominant	584.6
Luminous Intensity	
Purity	
Radiometric	2.2613
PAR	
PPFD	
Luminous Efficacy	89.7821

Rendering Indices	
Ra	96.4
R1	97.8
R2	98.7
R3	97.6
R4	97.0
R5	97.5
R6	97.4
R7	94.8
R8	90.3
R9	78.9
R10	95.7
R11	97.2
R12	88.2
R13	98.3
R14	97.7

Binning structure graphical representation

Binning structure graphical representation IEC 1976

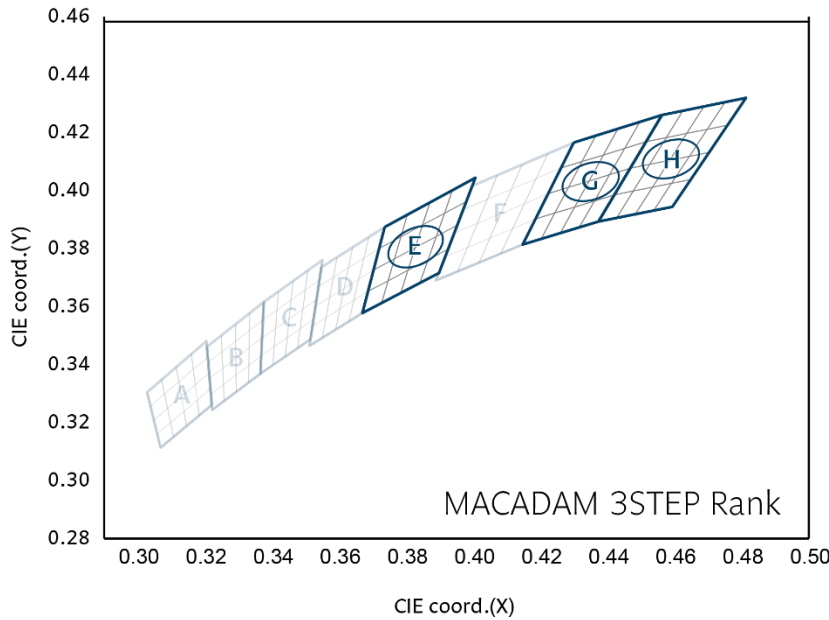

* Note that the Blue boxes represent Energy Star Rank

Short form in diagram	Colour Code	CCT
H	27	2700K
G	30	3000K
E	40	4000K

Colour Rendering Index (CRI)

CRI Code	CRI (min) Ra
8	>80
9	>90

Short form letters for CCT (K)

Colour Code	CCT
27	2700K
30	3000K
40	4000K



Electrical Optical Data

Voltage effect on light exchange

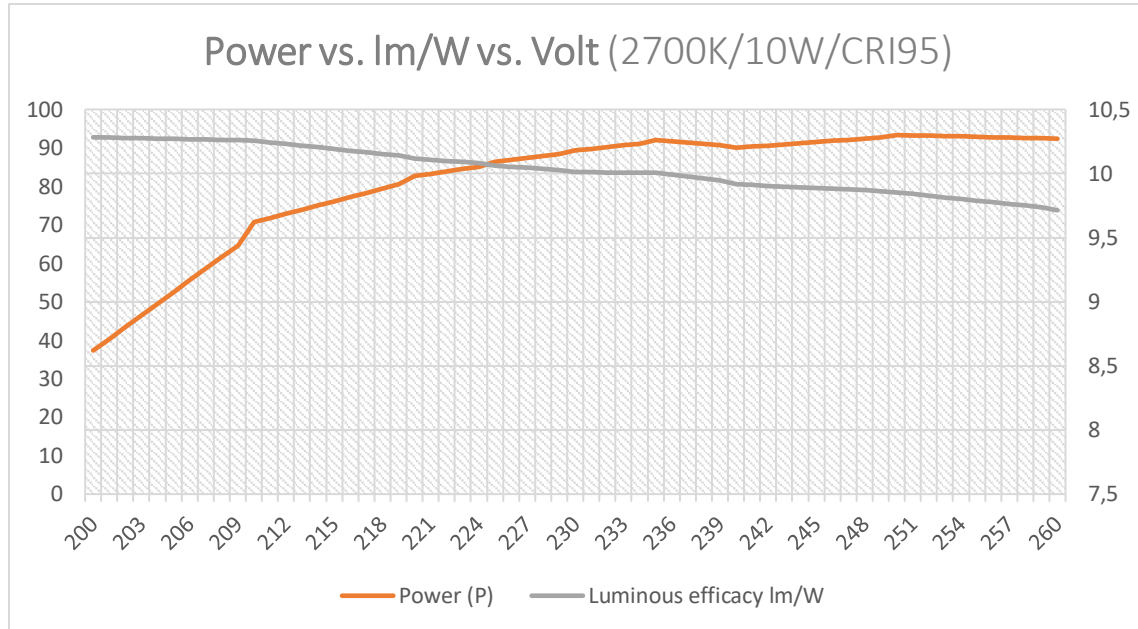

Temperature Characteristics

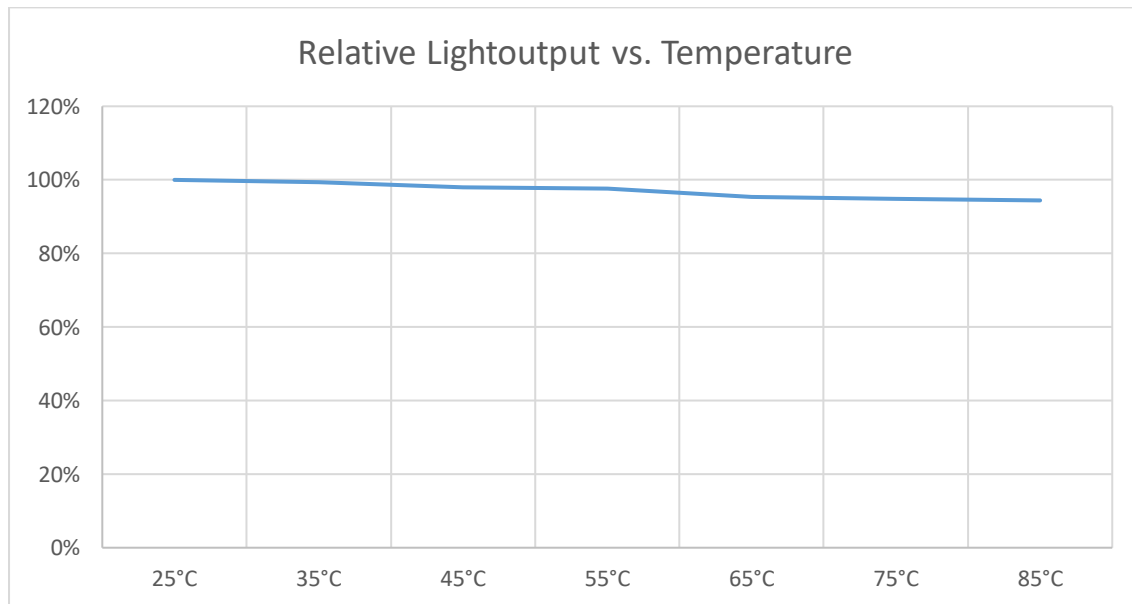

Consider the thermal properties where the LED module is to be mounted. Temperature is an important factor for lifetime longevity as well as for degradation of luminous flux.

Lifetime (Calculated)

TM 21 Interpolation

The lifetime is calculated at the maximum temperature recommended at the Tc (measuring point). It is important not to exceed this recommendation.

Predicted light output based on LED lifetime (LM80) performance <u>ONLY</u>				
	55°C	65°C	75°C	85°C
L70B10	>50 000h	>50 000h	>50 000h	>50 000h
L80B10	>50 000h	>50 000h	>50 000h	>50 000h
L90B10	>50 000h	>50 000h	45 000h	37 000h

Consider the thermal capabilities of where the LED module is to be fitted. The temperature is an important factor for light output as well as for long time light output degradation.

Measurement points

When the measurement takes place you verify that the temperature on the marked measurement points is satisfying. Pending on the result you know what lifetime to expect from the module. This step will be implemented after the heat sink has been connected properly!

Measurement Control

The recommended maximum value is 65°C on Tc or measuring point. If this value is exceeded we cannot guarantee the function and the lifetime of the product. The purpose of the measurement is to control the Junction (Tj) temperature of the LED and also in order to control the performance on the complete setup. By measuring the junction temperature (Tj) the average lifetime of the product is known.

The thermal connection is measured in temperature vs. Power.

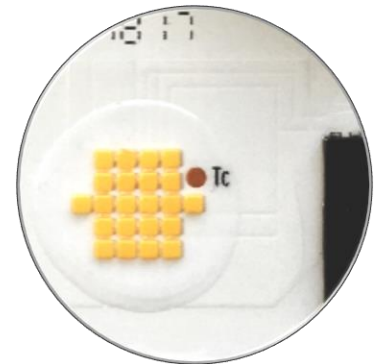

Maximum Temperature

Secure the temperature in your application not to exceed 65°C. Read more in the section "Measurement control".



Verification of Conformity

Radio Disturbance	IEC 55015:2006 + A1:2007 + A2:2009	
SURGE	IEC 61000-4-5	1 kv
Fast transient BURST	IEC 61547	2 kv
SAFETY	IEC 62031:2008	
Photo Biological Safety	IEC 62471:2008	
Radio Disturbance	IEC 55015:2006 + A1:2007 + A2:2009	
EMC	IEC 61000-3-2:2006	
EMC	IEC 61000-3-3:2008	
ESD*	IEC 61000-4-2	8 kv Air discharge 4 kv Contact discharge

* Please consult the document ESD standards on Optodrive ED, ID and AC

Production Setup

Production in accordance with IPC-6012-B and IPC-A-600G class 2

The LED Module is in accordance to EU Directive 2002/95/EC(ROHS)

The bare PCB is isolation tested with 3000VDC/10mA for 10 seconds

PCB Material Setup

In all questions regarding the bare PCB please use "Material Data sheet Optodrive" as a guideline.

Light fitting routine tests

According to EN/IEC 60598-1 should the routine test be performed as a dielectric strength test or insulation test. Only the insulation test of 500Vdc should be performed according to standard, 1s with min 2MΩ.

No dielectric tests are allowed to be performed on OptoDrive LED Modules.



DIMMERS tested

Brand	Model	Max W	Min W	Min %	Flicker (perceived)	Noise
ION	ID350WMKII	11,1	0,3	3%	No	No
ABB/Busch Jaeger	6523URJGL-214-103	9,6	0,7	7%	No	No
Elko	400GLI	9,8	1,2	12%	No	No
Niko	310-0190X	11,5	0,2	2%	No	No
Vadsbo	VD200	8,9	0,2	2%	No	No
Qlight	Monodim 350	10,7	1,9	25%	No	No
Schneider	SBD315RC	10,6	1,6	15%	Yes	No
SG	820320 LEDIM400	10,5	0,2	2%	No	No
Elko	315 GLE	10,4	1,9	18%	Yes	No
Gira	2262 00 / i01	10,1	1,3	13%	No	No
ABB/Busch Jaeger	2247U	10	1,2	12%	No	No
Q-light	Duo touchdim	10,5	3,3	31%	No	No
Q-light	Zerodim 350	10,5	0,8	8%	No	No
Ehmann	T14.03.1	8,2	2,7	33%	No	No
Vadsbo	VD300	10,7	0,5	3%	Yes	No
Gelia	EF700DC	10,3	3,9	3%	No	No
Schnider	SBD200LED	10,5	2,4	3%	No	No
ION	ID350WMKII	11,1	0,3	3%	No	No
Berker	2873	10,1	1,6	3%	No	No
Plejd	Dim-01	11,3	0,3	3%	No	No

It is important to understand that these are numbers tested with standard dimmers in a laboratory environment and can only be considered as reference information. Please always perform a test in its actual application. We take no responsibility for changes, differences and updates to dimmers and performance etc. due to this. In the test some of them had low or high level flicker but no problem changing up or down to make the perceived flicker go away. There is always flicker beyond the ability of the eyes to detect such and to minimize it, we recommend using DALI, Casambi, INGY or the like together with our DimIn system which almost completely removes this flicker.



Precautions for use

- *This device should not be used in any type of fluids such as water, oil, organic solvent etc.*
- *When cleaning is required, use only water together with mild soap on the outside of the lens. Cleaning inside of the LED module is strictly prohibited.*
- *The appearance and specifications of the product may be modified for improvement without notice.*
- *Long time exposure of sunlight or occasional UV exposure will cause lens discoloration.*
- *Opening of the LED module is prohibited due to risk of EMC, dust, grease and other exposures that will damage it.*
- *The LED Module should always be mounted to a proper heat sink before it's connected with its proper leads.*

Handling in regards to static electricity

- *The Optodrive products have integrated circuits (IC) on board that may be damaged if exposed to static electricity. Please handle the products only while using equipment that prevents static electricity. Do not handle them without having ESD protection.*
- *The Optodrive products are not be installed into the end product without proper ESD protection.*
- *Optodrive LED Modules meet IEC61547:2009 and IEC61000-4-2. We recommend the light fixture manufacturer to take the mentioned standards under consideration.*

Storage before use

- *Use only properly rated test equipment and tools for the rated voltage and current of the product being tested.*
- *It is strongly suggested to wear rubber insulated gloves and rubber bottom shoes while handling the product.*
- *Do not wear any conductive items (such as jewelry) which could accidentally contact electric circuits.*
- *Faults, lightning, or switching transients can cause voltage surges in excess of the normal ratings.*
- *Internal component failure can cause excessive voltages.*
- *Stored or residual electricity in long wire could be hazardous.*



ROHS III Compliant

All our LED modules meet the Restrictions of Hazardous Substances (RoHS III)!

There has been a growing consensus that Lead Free Systems should increase for the safety of our environment. It is a very serious problem that lead and other harmful materials are being used in commercial and industrial products, causing more and more environmental problems. This has led to regulations such as RoHS (Restriction of the use of certain Hazardous Substances) from the EU and the Japan Ministry of Trade and Industry (MITI). All LED module makers providing products to these countries should comply with these restrictions. In order to meet the RoHS III regulation, Optoga is strictly implementing a ban on lead and other hazardous materials in its products. This is in compliance with our responsibilities as good corporate citizens.

Design for Environment:

According to the EU-directive (RoHS III) the following substances must not be used in this product

- Lead (Pb)
- Mercury (Hg)
- Cadmium (Cd)
- Chromium VI (Cr⁶⁺)
- Polybrominated biphenyls PBB
- Polybrominated diphenyl ethers PBDE
- Bis(2-ethylhexyl) phthalate DEPH
- Butyl benzyl phthalate BBP
- Dibutyl phthalate DBP
- Diisobutyl phthalate DIBP

Do you want to know more about benefits of OptoDrive LED?

Read more about OptoDrive at www.optoga.com.

You can contact us via info@optoga.com.

You can also call us on +46 (0)589 490 950.

Optoga AB

Optoga was founded in November 2004 in Arboga, Sweden and has many years of experience in electronics design. The company develops and supplies LEDs and LED-module solutions for the lighting industry, vehicle manufacturers and electronics companies.

With the OptoDrive LED-module, Optoga has taken the initiative to replace strip lights, incandescent and halogen bulbs with LED-based sources.



Köpingsvägen 4 • SE-732 31 Arboga • SWEDEN

Tel +46 (0) 589 490 950

info@optoga.com • www.optoga.com

Copyright © 2017 Optoga AB. All rights reserved.