

LineMAX

R1A76

14 LEDs linear module for Daisy-Mini lens **5 YEARS WARRANTY** **CC** CONSTANT CURRENT



FEATURES

- PCB dimension: 280x20mm
- Up to 1117 lm
- Up to 193 lm/W
- CRI 80, 90
- Max Electrical Insulation 150V
- Max 3 LED boards in series
- Connection type: Wago 2065
- Long lifetime up to 72000h (LED LM80 available on request)
- Different options available:
 - o TW 2700+5700K (code: R1729)
 - o 14 White LEDs (code: R1A76)
 - o 28 White LEDs (code: R1A19)
 - o 560x20mm 56 LEDs (code: R1B63)
- [Suitable for LEDiL Daisy-Mini lens](#)

APPLICATIONS



Indoor



Commercial



Office

LineMAX

R1A76



14 LEDs linear module for Daisy-Mini lens **5 YEARS WARRANTY** **CC** CONSTANT CURRENT

High Efficiency LED

Code	CCT	CRI	Current [mA]	Voltage [V]	Power [W]	Total Lumen [lm]	Lm/W	Energy Efficiency
R1A76113080	3000K	80	150	38.6	5.8	1029	177	C
R1A76114080	4000K		150	38.6	5.8	1117	193	C
R1A7611BREAD	Bread	N/A	100	40.3	4	486	122	E
			200	43.3	8.7	870	100	F
R1A7611FISH	Fish		100	41.1	4.1	544	133	E
			200	44.4	8.8	952	108	F
R1A7611MAME	Marbled Meat		100	40.3	4	337	84	G
			200	43.3	8.7	597	69	G

Flux tolerance +/- 10%
Vf Tolerance +/- 5%

Ask for more information about available LED and other options.

Standard LED

Code	CCT	CRI	Current [mA]	Voltage [V]	Power [W]	Total Lumen [lm]	Lm/W	Energy Efficiency
R1A76113080	3000K	80	150	39.9	6	977	163	D
R1A76114080	4000K		150	39.9	6	1016	169	D
R1A7611BREAD	Bread	N/A	100	40.3	4	486	122	E
			200	43.3	8.7	870	100	F
R1A7611FISH	Fish		100	41.1	4.1	544	133	E
			200	44.4	8.8	952	108	F
R1A7611MAME	Marbled Meat		100	40.3	4	337	84	G
			200	43.3	8.7	597	69	G

Flux tolerance +/- 10%
Vf Tolerance +/- 5%

Ask for more information about available LED and other options.

LineMAX

R1A76



14 LEDs linear module for Daisy-Mini lens **5** YEARS WARRANTY **CC** CONSTANT CURRENT

LED and board features	
LED number	14
LED type	2835 (Dual color con request)
Circuit	S14P1
Material	FR4
Solder	White
Connections	
Cable	On request
Connector	Wago 2065 1P, 24-18 AWG
Power	
Abs. Max Input current CC	300mA
Mechanical Data	
H x L	279,6x20mm
Thickness	4.3mm
Conditions	
Max. temp. (Tp)	+95°C
Max. temp. (Tc)	+85°C
Operating temp. Range	-35°C + 60°C

LineMAX

R1A76



14 LEDs linear module for Daisy-Mini lens **5 YEARS WARRANTY** **CC** CONSTANT CURRENT

MECHANICAL DRAWING

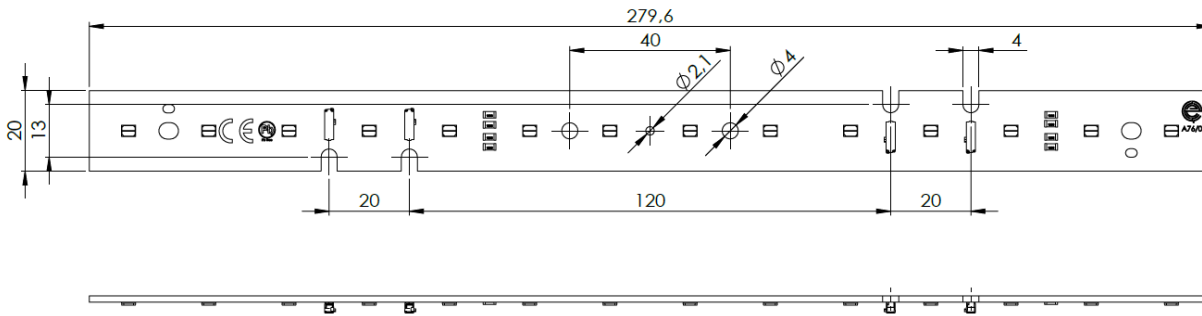

ELECTRICAL CIRCUIT

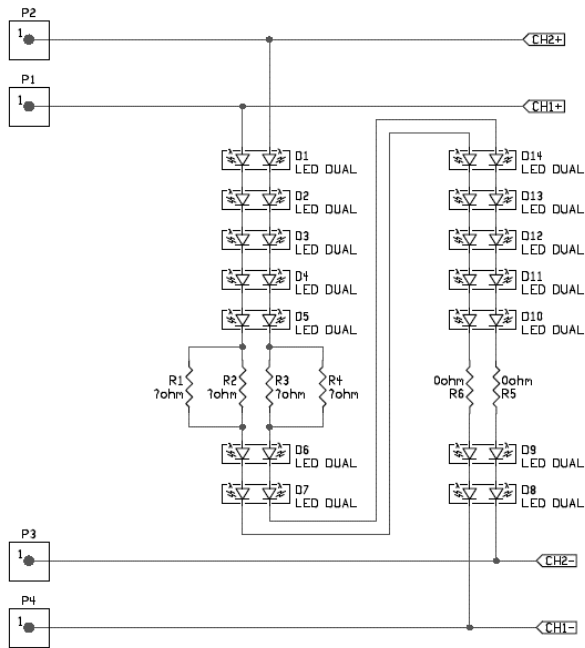

WIRING FOR SERIES CONNECTION SYSTEM



LineMAX

R1A76

Accessories: LEDiL Daisy-Mini lens

5 YEARS WARRANTY



CC CONSTANT CURRENT

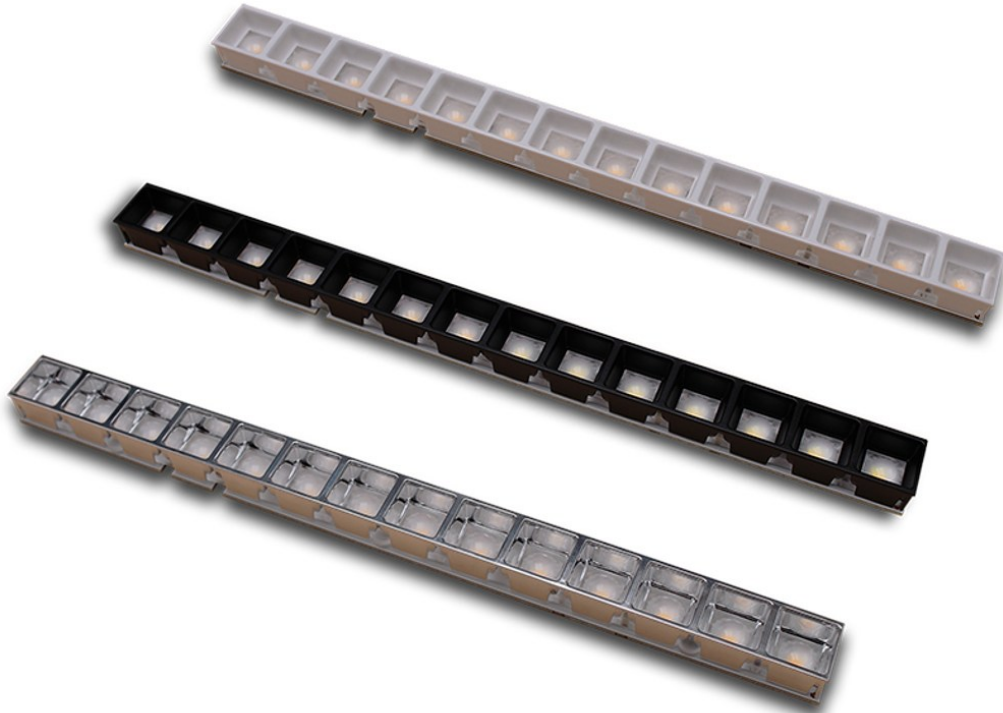

Specifications: Daisy-Mini 14X1	
View Angle (FWHM)	30°/40°/55°/65°/asymmetrical
Dimensions	280x21mm
Material	PMMA (lens) + PC (shade)
Operating Temperature - Optic	85°C max.

ASSEMBLY AND SAFETY INFORMATION

The LED modules are designed to be incorporated in a final appliance. Installation must be carried out under observation of the relevant regulations and standards. Installation must be carried out in a voltage-free state (i.e. disconnected from the mains).

Additionally, the following advice must be observed; non-observance can result in electrical, mechanical and/or fire hazards.

- ESD (electrostatic discharge) protection measures must be observed when handling and installing the LED modules.
- Transient protection measures (as per IEC 61000-4-5), especially for outdoor applications, must be observed (e.g. SPD).
- Adequate anti-static electricity measures, including the use of conductive shoes, ionizers, work bench grounding, wrist straps, flooring and stools should be used.
- LED assembly modules must not be subjected to any undue mechanical stress, e.g.:
 - Do not treat as bulk cargo.
 - Avoid sharing and compressive forces during handling and installation.
 - Do not damage circuit paths.
 - Avoid any pressure on the light emitting surface.
- Safe operation is only possible using proper external sources (e.g: constant current sources - I_{max}. see table "Electrical Characteristics").
- Operate only with power supply units that feature the following protection:
 - Short-circuit protection
 - Overload protection
 - Overheating protection
- The module can be fixed with M3 screws. They are recommended to be fixed only with flat or cylinder head screws (M3) (no countersunk screws – if not differently specified). Max. torque: 1.2 Nm (M3)
- Please ensure the correct polarity of the leads prior to applying power. Reversed polarity can destroy the modules.
- For interconnection, the LED modules are usually equipped with push-in terminals. Custom connectors are available upon request during the project bidding stage.
- General Safety regulations acc. to IEC/EN 60598-1 (or specific standards related to different lighting applications) must be observed.
- The following points must be observed when connecting LED modules in parallel:
 - All LED strings that are wired in parallel must contain the same number of LEDs (symmetrical loading).
 - Owing to differing forward voltage, there can be a difference of up to 10% in brightness between modules connected in parallel.
 - For this installation setup, please notify us when placing your order.
- To ensure problem-free operation, the specified maximum temperature at the tp point (see "Operating Life") must be observed (and measured in accordance with IEC 62717 – Annex H).
- In the event of outdoor applications or applications in damp locations, care must be taken to protect LED modules against humidity, splashes and jets of water. Any corrosion damage resulting from humidity or contact with condensation will not be recognized as a defect or manufacturing fault. LED modules are not specifically protected against foreign bodies or dust. Depending on the type of application, further protection must be provided to prevent ingress.
- Due to the manufacturing process, the PCBs of the LED modules can have sharp edges and corners. Care must therefore be taken during handling and installation to avoid injury.
- Constant current drivers require for an optimal usage that the modules are connected in series. For this type of usage, there must be ensured that the quantity of LED modules is limited by the sum of forward voltage and the capacity of used constant current driver. Safety regulations acc. to IEC/EN 60598 must be observed if the sum of forward voltage exceeds the permitted touchable value.
- There is a list of chemical substances (as sulfur) that has been proved to make the LED module damaged. Also, in chemically enriched (aggressive) environments the LED module functionality can be compromised, or they can even cause total module failure. Keep attention to this aspect before installing the LED module.
- The photobiological safety of the LED modules must be classified into risk groups in accordance with IEC/EN 62471 and IEC/EN 62471-7.

APPLIED STANDARDS

IEC / EN 62031

LED modules for general lighting – Safety specifications

IEC 62717

LED modules for general lighting - Performance requirements

IEC/EN 60598-1

Luminaires – Part 1: General requirements and tests

IEC/EN 62471

Photobiological safety of lamps and lamp systems

IEC 61000-4-5

Electromagnetic compatibility (EMC) – Part 4-5: Testing and measurement techniques – Surge immunity test