

LineMAX

R1812

5 LEDs linear module,
asymmetrical beam for wall washer



5 YEARS WARRANTY

CC CONSTANT CURRENT



FEATURES

- PCB dimension: 131x14mm
- Up to 1305 lm
- Up to 151 lm/W
- CRI 90
- Max Electrical Insulation 200V
- Max 14 LED boards in series
- Connection type: AVX Poke 70-9296
- Long lifetime up to 72000h (LED LM80 available on request)
- Suitable for wall washer applications

APPLICATIONS



Indoor



Commercial



Wall Washer

LineMAX

R1812

5 LEDs linear module,
asymmetrical beam for wall washer



5 YEARS WARRANTY

CC CONSTANT CURRENT

Code	CCT	CRI	Current [mA]	Voltage [V]	Power [W]	Total Lumen [lm]	Lm/W	Energy Efficiency
R1812002790	2700K	90	350	13.5	4.7	618	131	E
			500	13.7	6.8	851	125	E
			700	14	9.8	1138	116	F
R1812003090	3000K		350	13.5	4.7	658	140	E
			500	13.7	6.8	906	133	E
			700	14	9.8	1212	124	E
R1812004090	4000K		350	13.5	4.7	709	151	D
			500	13.7	6.8	975	143	E
			700	14	9.8	1305	133	E

Flux tolerance +/- 10%
Vf Tolerance +/- 5%

Ask for more information about available LED and other options.

LED and board features	
LED number	5
LED type	3535
Circuit	S5
Material	Aluminium
Solder	Black (White on request)
Connections	
Cable	2.5mm Contact 18-26 AWG Solid or Standed. Max ins. 2mm
Connector	2x AVX 70-9296 1P
Power	
Abs. Max Input current CC	1500mA
Mechanical Data	
L x H	131x20mm
Thickness	3,6mm
Conditions	
Max. temp. (Tp)	+95°C
Max. temp. (Tc)	+85°C
Operating temp. Range	-35°C +60°C

LineMAX

R1812

5 LEDs linear module,
asymmetrical beam for wall washer



5 YEARS WARRANTY

CC CONSTANT CURRENT

MECHANICAL DRAWING

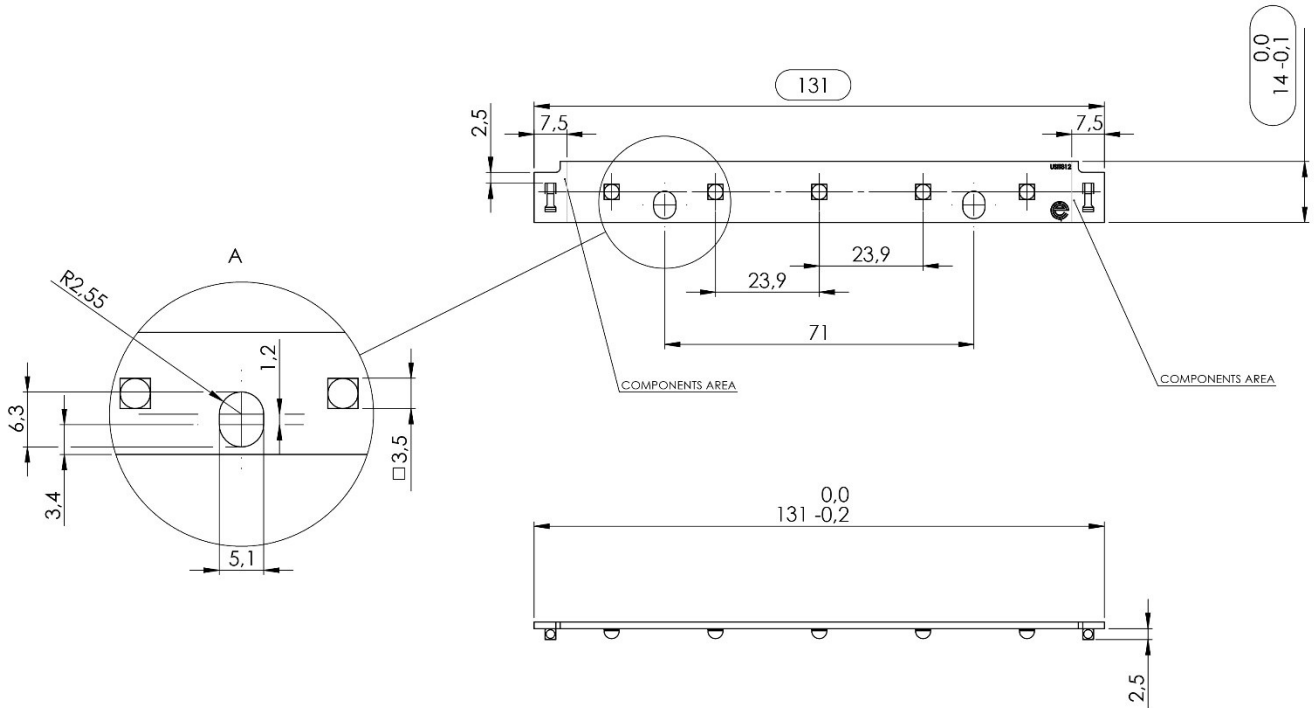

ELECTRICAL CIRCUIT



LineMAX

R1812

Accessories: reflectors



5 YEARS WARRANTY

CC CONSTANT CURRENT



Shade	
LLGXTD30-PTOP1	Black (Other colors on request)
Diffuser	
LLG-XTD-30-P-JP	Microstructural diffuser + Light chopper
Reflector	
LLG-XTD-30-P-R	Asymmetrical wall washer
Material	
PC	110°C

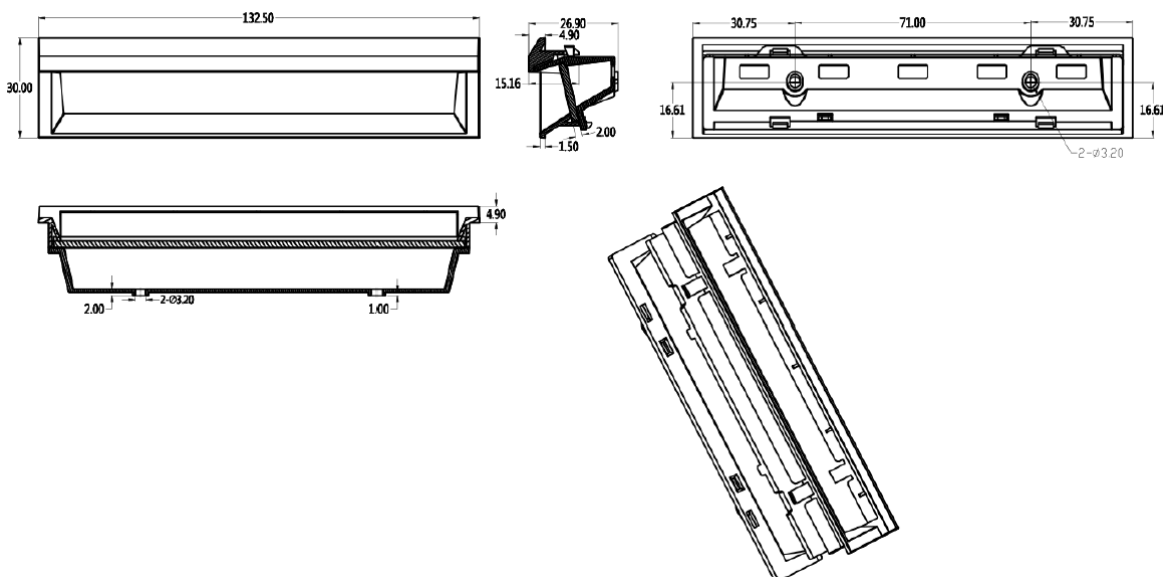

ASSEMBLY AND SAFETY INFORMATION

The LED modules are designed to be incorporated in a final appliance. Installation must be carried out under observation of the relevant regulations and standards. Installation must be carried out in a voltage-free state (i.e. disconnected from the mains).

Additionally, the following advice must be observed; non-observance can result in electrical, mechanical and/or fire hazards.

- ESD (electrostatic discharge) protection measures must be observed when handling and installing the LED modules.
- Transient protection measures (as per IEC 61000-4-5), especially for outdoor applications, must be observed (e.g. SPD).
- Adequate anti-static electricity measures, including the use of conductive shoes, ionizers, work bench grounding, wrist straps, flooring and stools should be used.
- LED assembly modules must not be subjected to any undue mechanical stress, e.g.:
 - Do not treat as bulk cargo.
 - Avoid sharing and compressive forces during handling and installation.
 - Do not damage circuit paths.
 - Avoid any pressure on the light emitting surface.
- Safe operation is only possible using proper external sources (e.g: constant current sources - I_{max}. see table "Electrical Characteristics").
- Operate only with power supply units that feature the following protection:
 - Short-circuit protection
 - Overload protection
 - Overheating protection
- The module can be fixed with M3 screws. They are recommended to be fixed only with flat or cylinder head screws (M3) (no countersunk screws – if not differently specified). Max. torque: 1.2 Nm (M3)
- Please ensure the correct polarity of the leads prior to applying power. Reversed polarity can destroy the modules.
- For interconnection, the LED modules are usually equipped with push-in terminals. Custom connectors are available upon request during the project bidding stage.
- General Safety regulations acc. to IEC/EN 60598-1 (or specific standards related to different lighting applications) must be observed.
- The following points must be observed when connecting LED modules in parallel:
 - All LED strings that are wired in parallel must contain the same number of LEDs (symmetrical loading).
 - Owing to differing forward voltage, there can be a difference of up to 10% in brightness between modules connected in parallel.
 - For this installation setup, please notify us when placing your order.
- To ensure problem-free operation, the specified maximum temperature at the tp point (see "Operating Life") must be observed (and measured in accordance with IEC 62717 – Annex H).
- In the event of outdoor applications or applications in damp locations, care must be taken to protect LED modules against humidity, splashes and jets of water. Any corrosion damage resulting from humidity or contact with condensation will not be recognized as a defect or manufacturing fault. LED modules are not specifically protected against foreign bodies or dust. Depending on the type of application, further protection must be provided to prevent ingress.
- Due to the manufacturing process, the PCBs of the LED modules can have sharp edges and corners. Care must therefore be taken during handling and installation to avoid injury.
- Constant current drivers require for an optimal usage that the modules are connected in series. For this type of usage, there must be ensured that the quantity of LED modules is limited by the sum of forward voltage and the capacity of used constant current driver. Safety regulations acc. to IEC/EN 60598 must be observed if the sum of forward voltage exceeds the permitted touchable value.
- There is a list of chemical substances (as sulfur) that has been proved to make the LED module damaged. Also, in chemically enriched (aggressive) environments the LED module functionality can be compromised, or they can even cause total module failure. Keep attention to this aspect before installing the LED module.
- The photobiological safety of the LED modules must be classified into risk groups in accordance with IEC/EN 62471 and IEC/EN 62471-7.

APPLIED STANDARDS

IEC / EN 62031

LED modules for general lighting – Safety specifications

IEC 62717

LED modules for general lighting - Performance requirements

IEC/EN 60598-1

Luminaires – Part 1: General requirements and tests

IEC/EN 62471

Photobiological safety of lamps and lamp systems

IEC 61000-4-5

Electromagnetic compatibility (EMC) – Part 4-5: Testing and measurement techniques – Surge immunity test